

# IR-B06 / IR-B06-T

## Short Wave Infrared Dryer



### User Manual for Short Wave Infrared Paint Curing Equipment

– Translation of German Original Document –

**EU-Declaration of Conformity According to DIN EN ISO/IEC 17050-1**

Manufacturer: B-TEC GmbH  
Zunftweg 6-8  
D-31303 Burgdorf / Ehlershausen



Herewith, we declare that the devices and marketed models described in the following conform in conception and in design to the relevant fundamental safety and health requirements of the applicable directives. This object of conformity is issued under the sole responsibility of the manufacturer. The object of the declaration is in conformity with the relevant Union harmonisation legislation. If you modify the device without our explicit agreement, this declaration will be invalidated.

Type of equipment: Paint drying equipment

Type designation: **IR-B06**  **IR-B06-T**

Serial number: \_\_\_\_\_

Year of construction: **20**\_\_

Parameters:	Rated voltage:	400 V
	Rated current:	16 A
	Rated frequency:	50 Hz
	Rated power input:	6300 W
	Protection class:	I
	Degree of protection:	IPX0

Tested according to:	EN 60335-1/A2:2006
	EN 60335-2-30/A2:2007
	EN 50366/A1:2006

This EU-Declaration of Conformity is issued on a voluntary basis according to the Low Voltage Directive 2014/35/EU relating to electrical equipment designed for use within certain voltage limits. It confirms that the listed equipment complies with the principal protection requirements of the directive.

Responsibility for technical documents: Michael Bellroth, Christian Bellroth  
Address: Refer to manufacturer's address

Hannover, 02.01.2020

Place, date, signature of manufacturer:  
Function of the signer: Managing director

## Table of Contents

1. Important Information .....	1
1.1. Explanation of the Symbols .....	1
1.2. Liability and Warranty .....	1
2. Safety Requirements .....	2
2.1. Working Area .....	2
2.2. Use .....	3
3. Technical Description and Intended Use .....	4
3.1. Technical Information .....	4
3.2. Wiring Diagrams .....	5
3.3. Spare Parts .....	6
4. Installation .....	7
5. Operating Instructions .....	8
5.1. Temperature Control (Only IR-B06-T) .....	9
5.2. Memory Function .....	9
5.3. Distance Control .....	9
5.4. Curing Times .....	10
6. Maintenance and Care .....	10
6.1. Replacing Emitter Tube .....	11
7. Troubleshooting .....	12

## 1. Important Information

We thank you for your trust you gave to us by purchasing this B-TEC device. On the type plate at your device you can find the exact type designation and serial-number of your infrared emitter to ensure an uncomplicated service and shipment of spare parts.

The B-TEC devices have been designed and manufactured to the highest quality standards for high operational safety. Due to certain operation processes, there are places and parts that can't be protected without impairing operability and functionality. Therefore we ask you to read this document carefully before using the device in order to achieve maximum operational safety and lifetime. The instructions are an integral part of the product and must be stored with the device.



**Read this document carefully before putting the device into operation and keep it for future reference!**

B-TEC devices are to be used solely in accordance with the intended use. Usage not in accordance with the intended use as well as unauthorised modifications invalidate the liability of the manufacturer for any damages resulting from this. Detailed information regarding intended use to as well as liability and warranty can be read in section 1.2 and 3.



**The B-TEC devices are only to be used according to the intended used. Improper use of the device can endanger the health of the operator.**

### 1.1. Explanation of the Symbols

To directly draw attention to important information in this operating manual, the symbols "Caution!" and "Notice!" are used. Please note that paragraphs with these symbols need particular attention.

#### Caution!



You will see this symbol whenever attention is drawn to situations in which danger to life can arise due to or during incorrect or improper operation. Pay special attention to these symbols and act carefully.

#### Notice!



You will see this symbol in the operating manual whenever your attention is being drawn to correct work procedures, economic ways of operating or when the devices may be damaged by incorrect operation.

### 1.2. Liability and Warranty

The infrared dryer is state of the art, tested and operationally safe. Liability for the function of the device is transferred to the operating company, if the device is improperly maintained or repaired by persons who are not authorised by the manufacturer and / or supplier, or if it's used against the intended use and the instructions of the user manual. The operator is obliged to operate the device only when in immaculate condition. The manufacturer is liable for errors or omissions - to the exclusion of further claims - only within the scope of the statutory warranty obligations. We reserve the right to make technical changes any time for continuous development and improvement of our products. Such changes, mistakes and misprints do not constitute a claim for damages. Only original spare parts and accessories are to be used. The manufacturer and / or supplier is not responsible for damages caused by ignoring the instructions in this operating manual. Warranty and liability conditions of the manufacturers and / or supplier sales and delivery terms are not extended by the above notes.

B-TEC warrants its products to be free from defects in materials and workmanship, for a period of 24 months on a one shift basis. In case of exceptional usage such as multiple-shift operation, the statutory warranty is shortened to 12 months (two-shift operation) or 8 months (three-shift operation). The period starts from the date the device is shipped from the factory. Emitter tubes are excluded from warranty. The guarantee expires prematurely if the customer or a third party undertakes inappropriate modifications or repairs or if the customer, in case of a defect, does not immediately take all appropriate steps to mitigate the damage and give the supplier the possibility of remedying such defect.

## 2. Safety Requirements



**The manufacturer is not liable for damages caused by changes of the device that have not been specifically authorised by the manufacturer. The removal or alteration of safety devices immediately voids the warranty and is an infringement of European safety standards.**

The device is built according to the state of the art and can be operated safely. However, this does not mean that the consequences of all operational failures are protected by technical measures. Dangers can arise from this device if it is used improperly or incorrectly. However, additional organizational measures have to be taken into account through certain workflows.

The manufacturer is not reliable for damages caused by the following situations:

- Disregarding the instructions described in the operating manual.
- Changing technical product parameters.
- Changing or disabling safety facilities.



**Read the operating instructions and safety requirements carefully before putting the device into operation and follow the instructions carefully!**

### 2.1. Working Area

- It is not allowed to use this device in an explosive or combustible environment; otherwise it may lead to fire.
- In case the device is used in a spray booth, the air must be exchanged/purified before use.
- Be careful of uneven floor when moving the device to avoid any overturn.
- Avoid any accident caused by random placement and dark lights. Please keep the site clean with enough light.
- Do not use this device when it is rainy or damp. Water coming into the device may lead to electric shock or damage to the device.
- For outdoor use, please use the outdoor-specific cables marked with “W- A” or “W” for avoidance of electric shock.
- Do not use this dryer in wet areas such as bathrooms or swimming halls. Keep the working site dry.
- Keep the working area clean and free of any obstructions, oil, waste article or other broken parts.

## 2.2. Use

- The operator is not allowed to operate the device after consuming alcohol or drugs, otherwise miss- operation of this device may lead to serious injury and even death.
- Proper Dressing: It is not allowed to wear too loose clothes and accessories. Please bind your hair if it is too long.
- Avoidance of Accidents: make sure that the power switch is closed when connecting with the power supply. The opened switch may result in accident.
- When the device is started, the wrench or any adjusting tools should be avoided to touch the live part of the device, which may result in electric shock.
- Any unconscious start of this device should be avoided.
- When you leave, make sure the power is shut down and unplugged.
- It is not allowed to knock or crash the equipment.
- It is not allowed to insert any hard object into the emitter.
- Before using remove any part of the packaging.
- Remove all objects in front of the pipe before starting.
- Persons should avoid the area 4 meters in front of the emitter tube. If necessary, protective equipment should be provided.
- This device should not be pointed at staff or highly flammable substances.
- Do not move the device during operations or shortly after. It can lead to premature failure of the emitter. Wait until emitter tube is cooled down.
- Do not cover the dryer in order to avoid overheating and fire. Do not use the dryer close to curtains and other combustible materials.
- Ensure that emitter tube cassettes are not pointed at each other.
- Don't misuse the electric wire. It is not allowed to drag the device with the power wire or pull the power plug. Please keep the power wire away from the hot, oily or sharp or movable objects. Please replace the damaged cables and wires as soon as possible for avoidance of electric shocks.

### 3. Technical Description and Intended Use

The short-wave infrared paint dryer is designed for curing of car body paintwork. The device offers high material penetration, short curing times, long service life and high performance. It's movable and convenient.

- Each emitter cassette can be activated separately.
- 2-Stage drying (Flashlight / Continuous).
- Cassettes can be rotated up to 300°.
- The height is adjustable.
- Curing time can be set via electronic timer.
- Permanent and automatic distance control by ultrasonic and adaptive temperature control.

#### 3.1. Technical Information

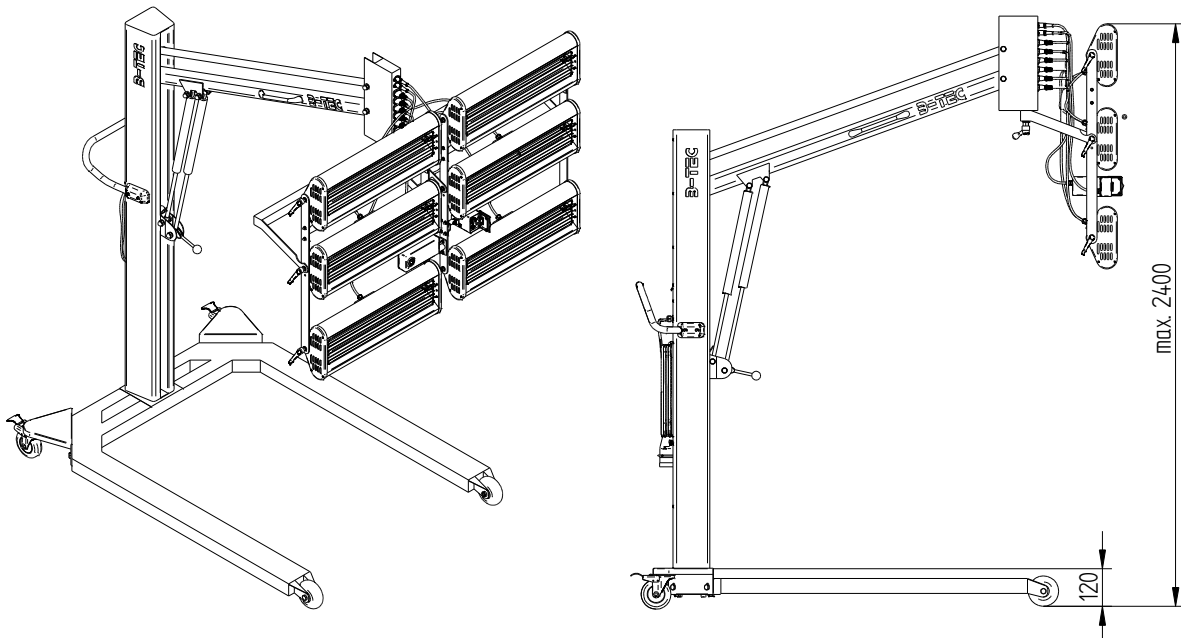

Input current	16 A
Input voltage	400 V - 50/60 Hz (3PH)
Max. power	6300 W (6 x 1050 W)
Curing area	1000 x 1500 mm
Curing time	1 - 35 min
Temperature	60°C - 70°C
Dimension (W x H x L)	1100 x 1250 x 1760 mm
*Max. overall height with cassettes: 2400 mm	
Digital display	✓
Pneumatic-aided lifting	✓
Ultrasonic distance measurement	✓
Temperature control	✓ (Only IR-B06-T)

**3.2. Wiring Diagrams**

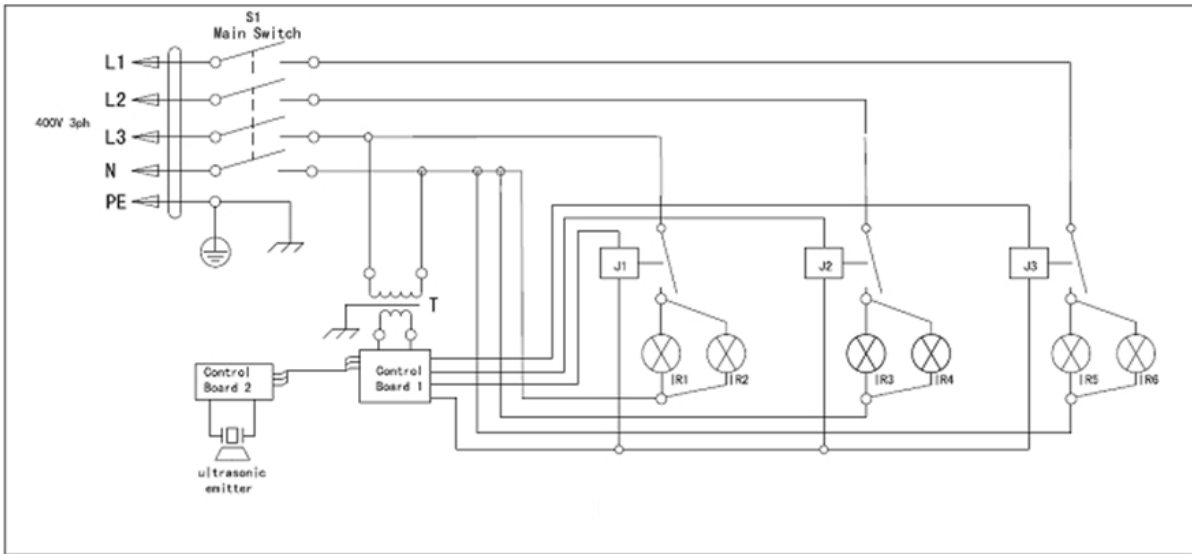

**Figure 3-1 – Wiring diagram IR-B06**

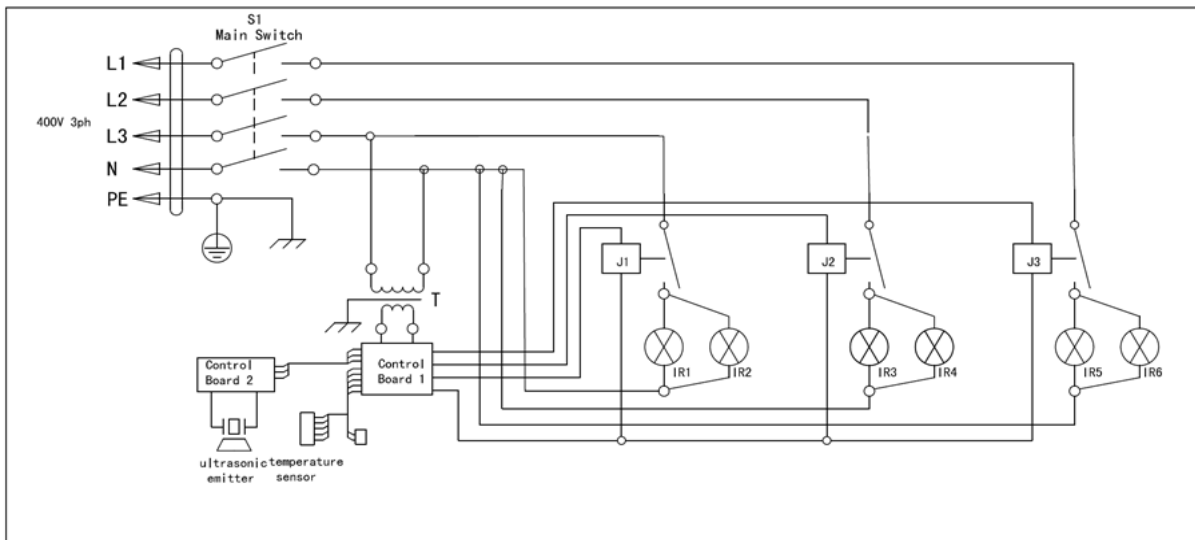

**Figure 3-2 – Wiring diagram IR-B06-T**

– Technical changes and errors reserved. All pictures similar –

### 3.3. Spare Parts

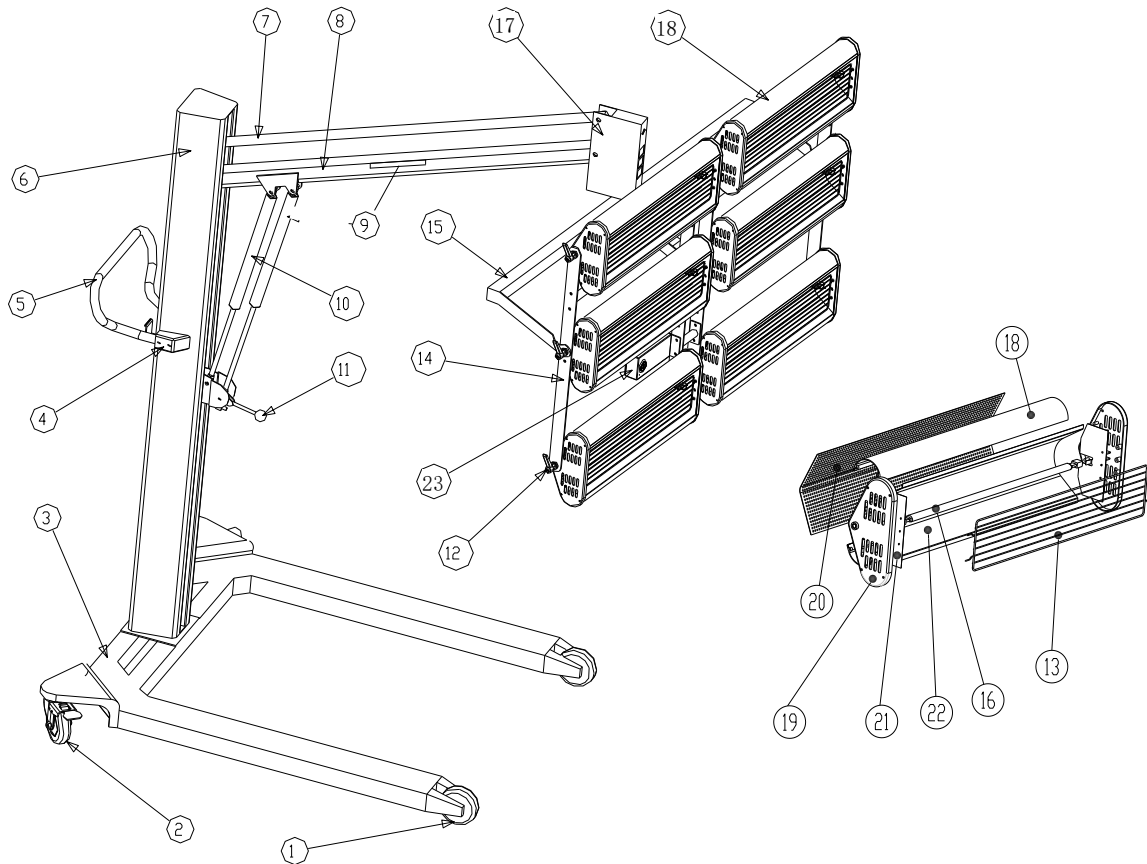

IR-B06 / IR-B06-T					
No	Name	Art-No	No	Name	Art-No
1	Front wheel	10000160	17	Armbox compl. incl. cable IR-B06	10001196
2	Swivel castor with brakes	10000161		Armbox compl. incl. cable IR-B06-T	10000187
3	Chassis	10001262		Socket for armbox	10000176
4	Handle socket	On request	18	Cover plate	10000164
5	Handle	On request	19	Side cover of emitter	10000165
6	Mainboard IR-B06	10001185	20	Heat dissipating plate	10000167
	Mainboard IR-B06-T	10000149	21	Small reflector plate	10000168
7	Arm (part 1)	On request	22	Large reflector plate	10000169
8	Arm (part 2)	On request	23	Ultra-sonic distance sensor	10000185
9	Handle for arm, black	10000144	-/-	Relay 10 A	10000174
10	Hydraulic damper front incl. lever	10000194	-/-	Relay 25 A	10000180
	Hydraulic damper rear	10000188	-/-	Temperature control	10000151
11	Lever with ball knob	10001184	-/-	Toggle big	10000157
12	Toggle small	10000158	-/-	Plug with cable for cassette	10000175
13	Protective grid	10000159	-/-	Emitter cassette incl. infrared tube	10000196
14	Emitter cassette connector	On request			
15	U-Shape support	10000186	-/-	Transformer, 230V/830mA	10000197
16	Infrared tube	10000162	-/-	Main switch	10000973

– Technical changes and errors reserved. All pictures similar –

#### 4. Installation

1. Connect the wheel fixation pedestal ② and the rear wheels ③ to the pedestal ①.
2. Fix the column ④ on the pedestal ①.



**Do not push the lever with ball knob ⑤, otherwise arm can move up and cause injury. Do not twist the ball knob to avoid malfunction.**

3. Mount the emitter group ⑱ directly to the box of the arm ⑰.
4. Attach the power wires (A-F and distance sensor) into the associated sockets at the junction box.
5. Remove the sticker from the protection cover.
6. Remove the red foam cubes behind the tube.

#### Notes:

- Living core (brown), neutral wire (blue), earth wire (green/yellow).
- Power supply: 16 A, 3 PH, 400V/50Hz.
- The device has to be protected by a 16-Ampere-fuse. A fuse with characteristic C for high starting currents is recommended.
- When moving the emitter group up and down, use one hand to hold the Cross arm on the handhold and push the pneumatic handle with ball knob ⑪ with the other hand.



**Move the cross arm only by using the handle, otherwise risk of injury!**

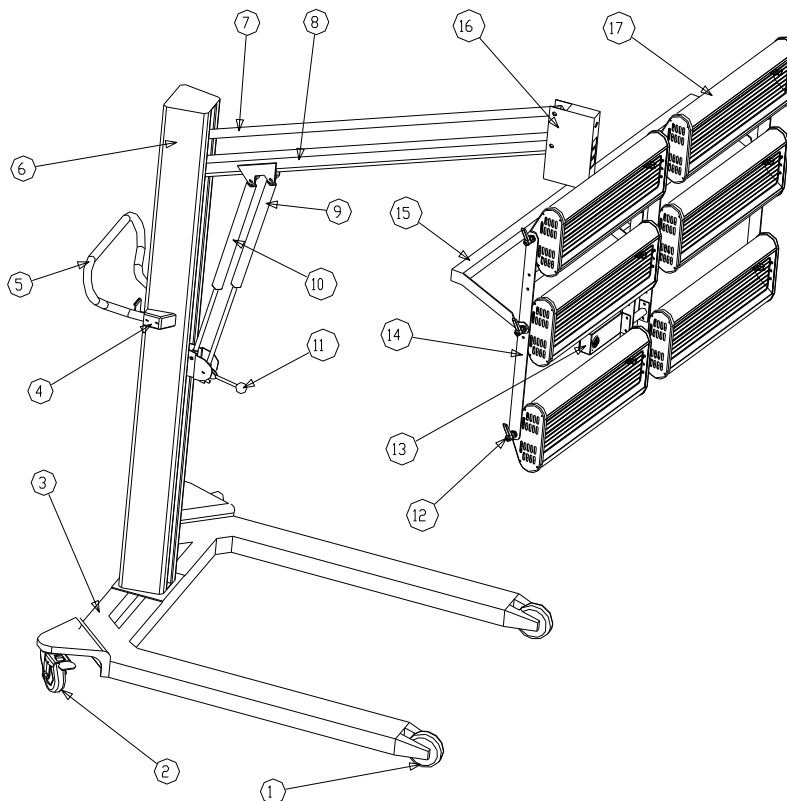

– Technical changes and errors reserved. All pictures similar –

## 5. Operating Instructions

### Notes:

- Power supply: 1PH 230V 50/60HZ
- Do not touch the lens cap during and after curing to avoid burns.

- |   |                              |
|---|------------------------------|
| (1) Time display                          | (10) Start/Stop              |
| (2) Memory function                       | (11) Power switch            |
| (3) Start/Stop emitter cassette           | (12) Target temperature      |
| (4) Start/Stop emitter cassette           | (13) Temperature in °C       |
| (5) Start/Stop emitter cassette           | (14) Temperature display     |
| (6) Timer for pre-curing (Flashlight)     | (15) Actual temperature      |
| (7) Timer for full-curing (Continuous)    | (16) Temperature setting +/- |
| (8) Ultrasonic distance control           | (17) Temperature in °F       |
| (9) Pause (1x for pause, 2x for stopping) |                              |

When the device is working or paused, buttons (2), (6) & (7) are disabled and will be reactivated when the working process is finished and/or device has stopped.

1. Choose the optimal distance between emitter and car body. The optimal distance is approximately 50 cm. (If distance control is used, see instructions further below).
2. Use the lever with ball knob to adjust the emitters to the needed height.
3. Adjust the direction of the emitters. They emitter tubes have to be parallel to the car body.
4. Tighten the toggles and activate the brakes of the rear wheels to avoid any accident due to unintended movements of the device.
5. Turn on the power switch (11).
6. Set pre-curing (Flashlight) time (6). Depending on material choose between 1 - 35 minutes. Default setting is 15 minutes. Set to 0 minutes, if no pre-curing required.
7. Set full-curing (Continuous) time (7). Depending on material choose between 1 - 35 minutes. Default setting is 15 minutes. Set to 0 minutes, if no full-curing required.
8. Activate the ultrasonic distance control (8) and find the optimal distance. The optimal distance is indicated by the green indicator light of the sensor.
9. Point the laser on the part to be dried and set the temperature control as described in section 5.1 (Only IR-B06-T).
10. Choose emitter cassette(s) (3/4/5).
11. Press Start/Stop-button (10).
12. Press the pause button (9) once to pause the device and press Start/Stop-button to continue curing. Press pause button (9) twice to shut down the emitter.
13. When the time is up, an acoustic signal occurs and the device shuts down.

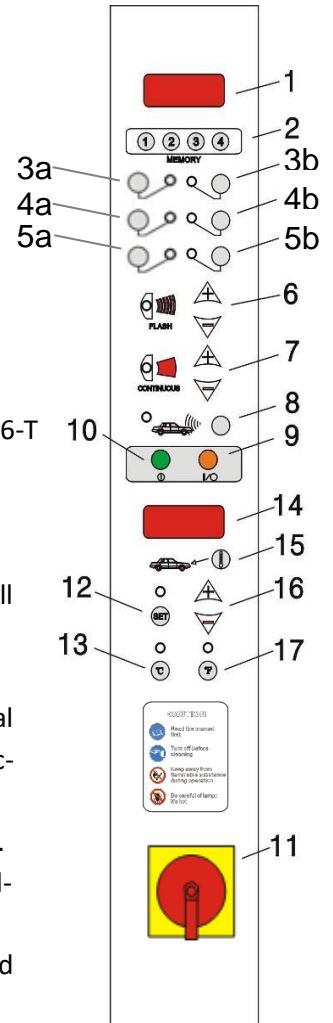

### 5.1. Temperature Control (Only IR-B06-T)

1. Press Start key (15) and the temperature display (14) shows the actual temperature of the car body.
2. If you want to check the defined target temperature, press the button (12) and the temperature display (14) shows the pre-set target temperature. **The default temperature is 70°C (150°F).** When the object has reached the target temperature, the device pauses automatically and will restart curing when the actual temperature has decreased and is lower than the target value.
3. To adjust the target temperature, press button (12) and set the new target temperature with +/- (16). Press button (12) again. The display switches off and the new target temperature has been saved.
4. The new target temperature remains effective as long as the device is not shut down. After the device is shut down, it will resume to the default value automatically.
5. **Attention: Please keep the thermometer lens clean and dust-free!** Close the dust-proof cover when you don't use the temperature measuring function. If it is necessary to clean the lens, open the front cover of the temperature measuring unit.



**It's recommended not to exceed a temperature of 70°C (150°F) when drying a part made of plastic in order to avoid damages. In case of uncertainty please ask the manufacturer of the part to be dried for information regarding heat resistance.**

### 5.2. Memory Function

1. Set proper pre-curing and full-curing time according on the paint type.
2. Press and hold one of the four memory buttons for 4 seconds, the pre-curing and full-curing time will be stored in this button. Four different settings can be stored.
3. When you need the stored setting, press the corresponding key.
4. To reset a memory button, repeat steps (1) & (2) to store new settings.

### 5.3. Distance Control

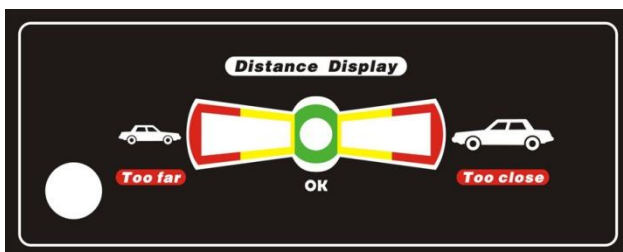

1. Left red indicator: Distance is too far.
2. Left yellow indicator: Distance is rather far.
3. Green indicator: Distance is suitable.
4. Right yellow indicator: Distance rather close.
5. Right red indicator: Distance is too close.

#### 5.4. Curing Times

The quality of the drying result highly depends on the share of pre-curing time in the total curing time. The higher the share of pre-curing (flashlight), the better might be the drying result. Too fast drying may lead to small pores / bubbles. As reference value a ratio of 1/3 pre-curing (flashlight) to 2/3 full-curing (continuous) is recommended. All values are reference values. For exact values please contact your paint supplier.

Material / Paint type	Total curing time in minutes
Putty	5-6
Filler	6-7
Primer	6-8
Water base	5
Base coat	6-10
Top coat	8-12
Clear coat	7-12
Filler on plastic	9-12
Top coat on plastic	17-19
Clear coat on plastic	17-19

#### 6. Maintenance and Care

- Regular cleaning of tubes and reflector plate should be done by using a piece of soft cloth or cotton with alcohol (Note: cleaning must be done after the device is disconnected from power supply and cooled down). Don't start the device until the alcohol has evaporated, otherwise it may lead to ignition.
- The device has to be protected by a 16-Ampere-fuse. A fuse with characteristic C for high starting currents is recommended.
- The device should be well grounded for safety. The grounding device should be connected to the proper output port under correct direction. Unauthorized alteration or change of output port is strictly prohibited. Use of any outlet converter is also not permitted. For any uncertainty, please find a professional electrician to check whether the grounding is correct. Please make sure the device is well grounded to avoid electric shocks.
- If the cable is damaged, contact the manufacturer, service provider or a professional to replace it in order to avoid injuries and accidents. Please replace damaged cables and power lines as soon as possible to avoid electric shocks.
- For replacing an emitter tube, ask the repair service center or a technician to do so.
- If an emitter tube does not start working, it may result from a loose socket/cable. Switch off the device and check the sockets.

## 6.1. Replacing Emitter Tube



**Interrupt the power supply, before replacing the infrared tube!**

Do not touch the reflector or the new IR tube with your fingers. Only remove the protective paper on the IR tube when it's finally installed.

1. Loosen the screws on the side cover of the cassette and remove it.
2. Release heat dissipating plate.
3. Disconnect the cables of tube.
4. Remove the protective grid
5. Remove the old tube and replace it by a new tube.
6. Reassemble in reverse order.

Use a piece of soft cloth or cotton to clean the reflector plate and the tube with alcohol. Cleaning must be done after the device is disconnected with the power and cooled down. Don't start the device until the alcohol has evaporated, otherwise it may lead to ignition.

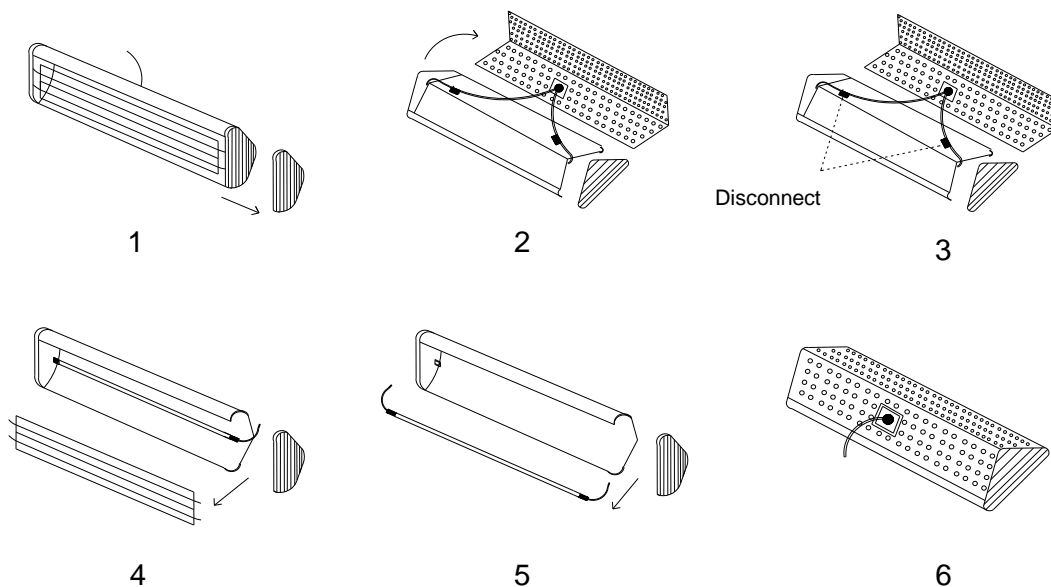

## 7. Troubleshooting

Issue	Possible cause	Possible solution
Uneven curing	<ul style="list-style-type: none"> <li>• Emitter not properly pointed/adjusted to the curing surface</li> </ul>	<ul style="list-style-type: none"> <li>• Adjust emitter properly to the curing surface</li> </ul>
Small pores (bubbles) on the cured surface	<ul style="list-style-type: none"> <li>• Emitter too close to curing surface</li> <li>• Curing too fast</li> <li>• Paint with fast thinning agent</li> </ul>	<ul style="list-style-type: none"> <li>• Increase distance</li> <li>• Increase pre-curing time</li> <li>• Use standard or slow thinning agent</li> </ul>
Poor curing or transparent coating	<ul style="list-style-type: none"> <li>• Emitter too far away from curing surface</li> <li>• Curing time too short</li> <li>• Paint layer too thick</li> </ul>	<ul style="list-style-type: none"> <li>• Decrease distance</li> <li>• Increase full-curing time</li> <li>• Apply thinner paint layer</li> </ul>
Stains	<ul style="list-style-type: none"> <li>• Full-curing time too long</li> <li>• Emitter too close to curing surface</li> </ul>	<ul style="list-style-type: none"> <li>• Decrease full-curing time</li> <li>• Increase distance</li> </ul>
Fuzzy edges	<ul style="list-style-type: none"> <li>• The painted surface area is too large for the infrared emitter</li> </ul>	<ul style="list-style-type: none"> <li>• Curing in two steps</li> <li>• Move device for second curing step</li> <li>• Pre-curing only for first step. Do not use pre-curing for second step.</li> </ul>

For optimal curing performance, we recommend to work out the optimal operating procedures, curing times and distances according to the local natural conditions, working environment and the types of paints used.

Above specifications, drawings or diagrams are descriptive and subject to revision. If there are any discrepancies or changes, actual products shall prevail without otherwise notification.